NEEDLE DEPTH ADJUSTMENT

PURPOSE:

The needle must rise 2-3 mm from bottom dead center thus forming a loop behind the needle. As the hook point passes behind the needle it captures the formed loop. If the Needle Bar is too high or too low the sewing quality is effected. The needle can not capture the loop therefore a stitch will not be formed or not form properly.

CAUSES:

- < Red caps worn or broken.
- < Broken needle.
- < "Slam" into hoop.
- < Changed needle brand.

SYMPTOMS:

- < Skip Stitches
- < Looping
- < Fraying
- < Breaking Thread
- < Breaking Needles

TOOLS NEEDED

- 3 mm T-handle Allen Wrench
 - 2.5 mm Allen Wrench
 - Phillip Screwdriver
 - Needle Screwdriver
 - New Needle
 - Cleaning Brush
 - Flashlight
-

PROCEDURE:

1. Using the **Automat/Controller**, position Sewing Heads to **Needle #1**.
2. **Power** down Embroidery Machine

3. **Pull** Thread Keep Lever to **left** to disengage thread apron clamps. See *Figure 1*.

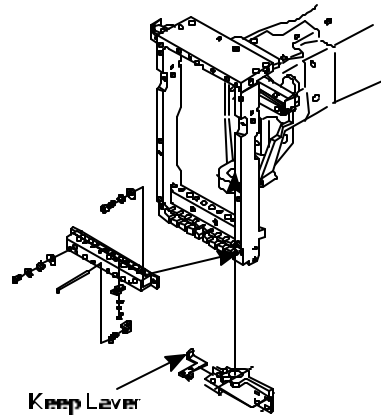

Figure 1

4. **Disengage** Needle Bar Driver.
5. Using a Phillips Screwdriver, **remove** 6 screws from A, B Sewing Head Plates and Thread Guide . See *Figure 2*.

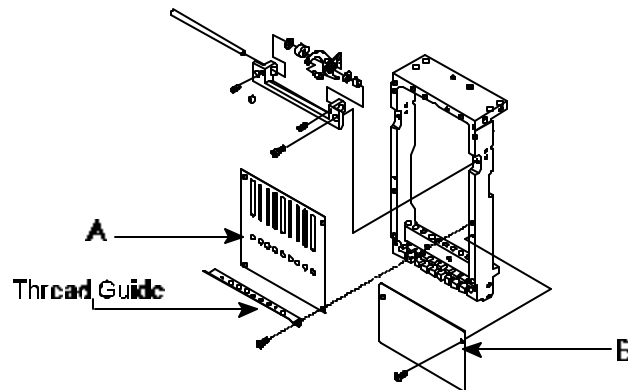

Figure 2

Note: When removing Sewing Head Plate **A** from **Sewing Head Number One**, lift straight up then pull towards you. Back side of cover wraps around the needle position indicator and incorrect removal can damage the indicator.

6. Using a 2.5 mm Allen Wrench, **remove** throat plate screws.
7. **Remove** throat plate.
8. **Remove** bobbin case from Hook Assembly.
9. Using **cleaning brush**, clean any thread debris or lint from hook area.
10. While Standing in front of training sewing head, **rotate** gangshaft until Take-up Levers are in up position, this is called **Color Change Position**. (On Embroidery Machine rotate degree wheel [numbers ascend] to 244 degrees).
11. **Remove** thread from Needle #1.
12. Using Needle Screwdriver, **loosen** needle set screw.
13. **Remove** and **discard** old needle.
14. **Insert new needle** correctly. (Groove facing front and scarf is in back.)
See *Figure 3*.

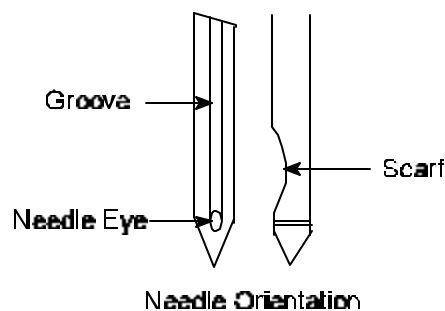

Figure 3

15. Using Needle Screwdriver, **tighten** needle set screw.
16. **Engage** Needle Bar Driver.
17. **Rotate** gangshaft so needle is at its lowest point (**Bottom Dead Center**). (Rotate degree wheel to **zero degrees** this is called **Bottom Dead Center**).

18. Before making any adjustments see if needle eyelet is positioned halfway through hook basket. See Figure 4.

If needle eyelet looks out of position proceed to **Step 19**.

If **no** adjustments are necessary proceed to **Hook Timing**.

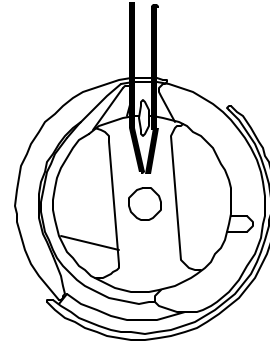

Figure 4

19. Using 3 mm Allen Wrench, **loosen** top and bottom hex socket bolts on Needle Bar Driver Fixing Base. See Figure 5.

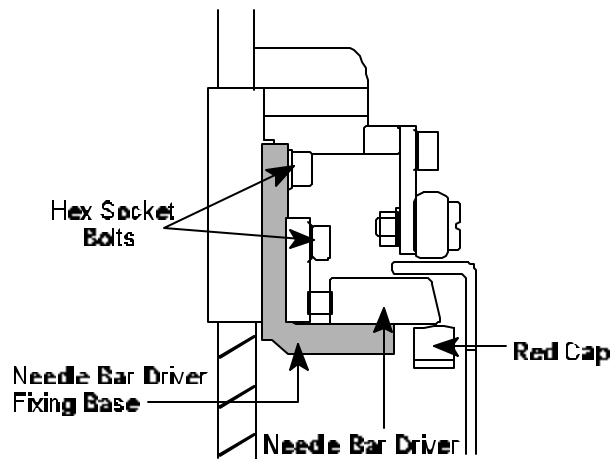

Figure 5

- < **Check** for damage to Needle Bar Driver, Needle Bar Driver Fixing Base and Red Cap.

Replace damaged parts.

20. **Adjust** by moving Needle Bar driver up or down so ½ of needle eyelet is viewed in hook basket.
21. While holding needle bar down, using a 3 mm Allen Wrench, **tighten upper** hex socket bolt to set Needle Bar driver.
22. **Recheck** needle depth. (As bolts are tightened needle bar driver may lower needle eyelet.)
23. If no adjustments have to be made, using a 3 mm Allen Wrench, **tighten lower** hex socket bolt.
24. **Rotate** gangshaft to **Color Change Position**. (Rotate degree wheel to 244 degrees).
25. **Reinstall** throat plate.
26. Using 2.5 mm Allen Wrench, **tighten** throat plate screws.
27. **Reinstall** bobbin case.
28. Using Phillips Screwdriver, **replace** Sewing Head Plates and Thread Guide.

Helpful Hint: Replace bottom plate (B) first then top plate (A) and Thread Guide.

29. Using enclosed disk, **sew** the “**HOX**” test to check for proper adjustment.

Note: If symptoms are still occurring proceed to **Hook Timing**.

HOOK TIMING

Hook timing is probably the most misunderstood aspect of embroidery machine mechanics. It has nothing to do with the type of fabric, tension or synchronization of the heads on a multi-head machine.

PURPOSE:

Hook timing is the proper position of the Hook Assembly in relation to the needle in order to form a stitch. The hook is directly attached to the drive shaft, eliminating the need to routinely re-time it.

CAUSES:

- < Something gets caught in Hook Assembly.
- < Size of needle has drastically changed.
- < A build-up of thread behind hook pushes hook out of line.

SYMPTOMS:

- < Machine fails to form or complete a stitch.
- < Excessive Needle Breaks.
- < Thread Frays
- < "Birdnesting"

PROCEDURE:

Needle depth must be checked before timing the hook.

A. PREPARATION

1. Using **Automat/Controller** position Sewing Heads to Needle #1.
2. **Power down** Embroidery Machine.
3. **Disengage** Needle Bar Driver.

TOOLS NEEDED

2.5 T-Handle mm Allen Wrench
Flathead Screwdriver
Needle Screwdriver
Offset Screwdriver
New Needles
Cleaning Brush
Emery/Crocus Cloth
Flashlight

4. **Pull** Thread Keep Lever to **left** to disengage thread apron clamps. See *Figure 1*.

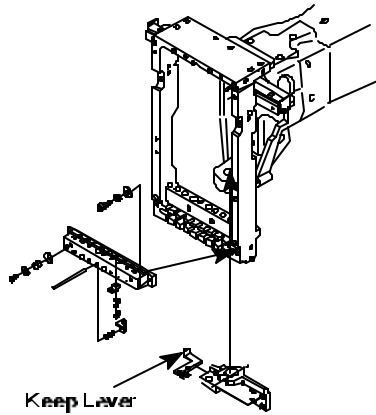

Figure 1

5. Using a 2.5 mm Allen Wrench, **remove** throat plate screws.
6. **Remove** throat plate.
7. **Remove** bobbin case from Hook Assembly.
8. Using **cleaning brush**, clean any thread debris or lint from hook area.
9. **Rotate** gangshaft until Take-up Levers are in up position. (On Embroidery Machine rotate degree wheel [numbers ascend] to 244 degrees).
10. With finger, **check** entire Hook Assembly for burrs or nicks.

*If burrs or nicks are present on Hook Assembly proceed to **Section B**.*

*If Hook Assembly is **not** damaged proceed to **Section C**.*

B. HOOK ASSEMBLY REPLACEMENT

11. Using an Offset Screwdriver, **remove** Position Finger **screw**. See *Figure 2*.

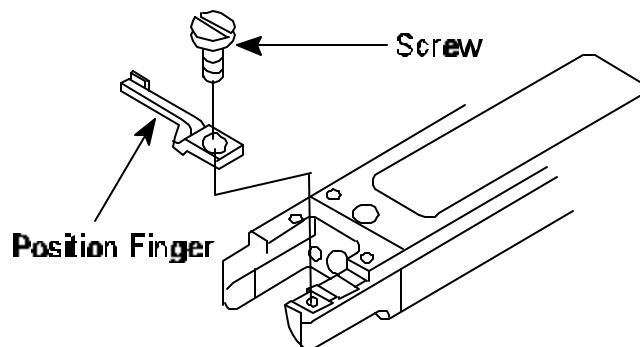

12. **Remove** Position Finger. See *Figure 2*.
13. **Remove** Hook Driving Rod from Hook (Fork).
14. **Release** Hook (Fork). (This allows Hook Assembly to be removed easily).
15. Using a Flathead Screwdriver, **loosen** three set screws on Hook Assembly.
16. **Remove** Hook Assembly.
17. Gently rub burred or nicked area of Hook Assembly with emery or crocus cloth until smooth.

Note: If burrs or nicks can not be smoothed, **replace** with new Hook Assembly.

18. **Rotate** gangshaft to **Color Change Position**. (Rotate degree wheel to 244 degrees).
19. **Replace** repaired or new Hook Assembly on bottom shaft.
20. **Rotate** Hook Point to 9:00 position.
21. **Snug** set screw closest to Hook Point.
22. **Replace** Position Finger.
23. **Insert** Position Finger **screw**. (Do not tighten completely).

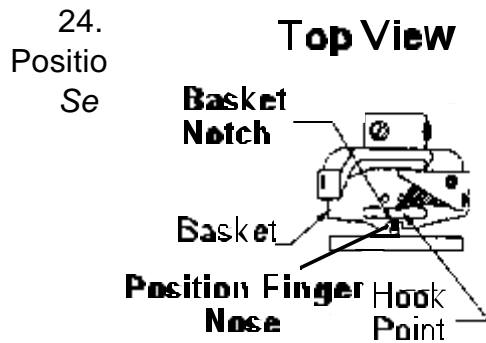

Figure 3

Rotate Basket until Basket Notch is aligned with Position Finger Nose. See Figure 3 and 4.

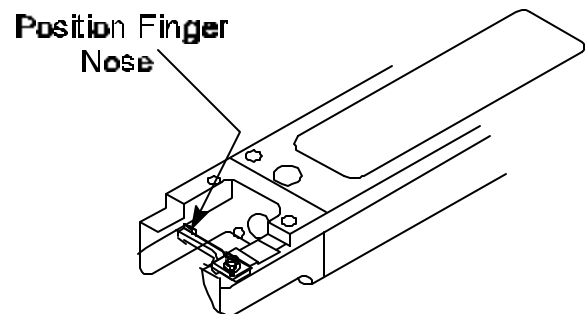

Figure 4

25. Using an Offset Screwdriver, **tighten** Position Finger screw.

26. **Replace** Hook Driving Rod.
27. **Rotate** gangshaft to **Color Change Position**. (Rotate degree wheel to 244 degrees).

C. HOOK POINT TIMING

28. **Remove** thread from Needle #1.
29. **Loosen** needle set screw.
30. **Remove** and **discard** old Needle.

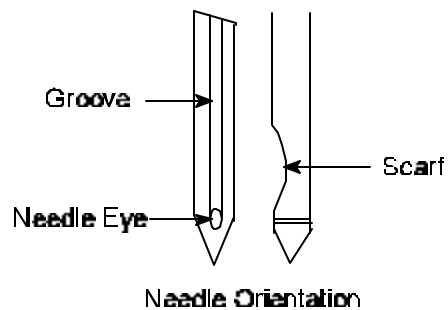

Figure 5

31. **Insert new needle** incorrectly. (Groove facing back and scarf is in front).
See Figure 5.
32. Using Needle Screwdriver, **tighten** needle set screw.
33. **Engage** Needle Bar Driver.

34. **Using** a needle screwdriver, **loosen** two set screws **furthest** from hook point leaving the set screw closest to hook point tight. (If Hook Assembly was removed as instructed in Section B, two set screws are already loose). See Figure 6.

(Degree Wheel: First screw=115 degrees; Second screw=175 degrees)

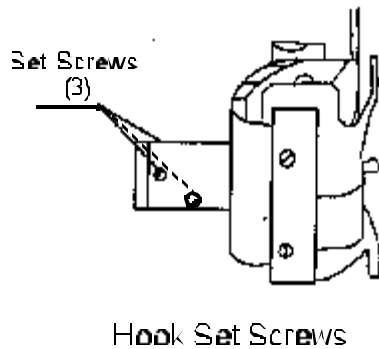

Figure 6

35. **Rotate** gangshaft so needle is at its lowest point (**Bottom Dead Center**). (Rotate degree wheel to **zero degrees**).
36. Continue turning gangshaft until **needle rises 2 to 3 mm**. (Rotate degree wheel to 24 degrees.)

Point of hook should be directly behind scarf of needle and above needle eyelet. See Figure 7.

If hook point **needs** adjustment proceed to **Step 37**.

If hook point **does not** need adjustment proceed to **Section D Hook to Needle Gap**.

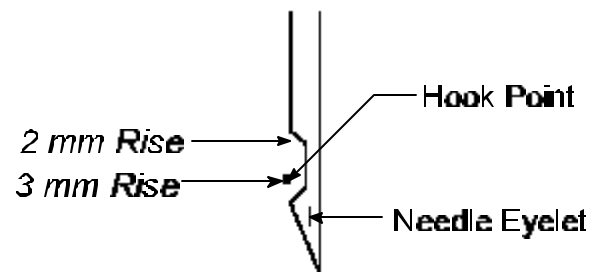

Figure 7

37. Using Flathead Screwdriver, **loosen** remaining set screw (closest to hook point).
38. Adjust so tip of hook point is behind and in **middle of needle**. See Figure 8.

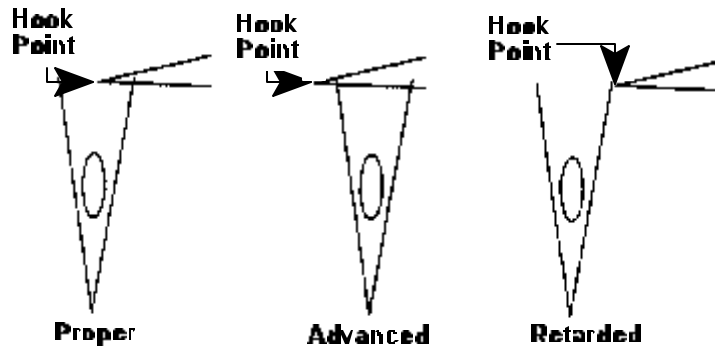

Figure 8

39. Using Flathead Screwdriver, **tighten** set screw closest to hook point

D. HOOK TO NEEDLE GAP

Hook Point must be directly behind needle and as close to needle as possible. (Should not cause needle to bend).

Proceed to **Step 40** if adjustments have to be made to gap.

Proceed to **Step 51** if no adjustments have to be made to gap.

40. Using a Flathead Screwdriver, **loosen** set screw closest to Hook Point.

41. **Adjust** Hook Assembly by moving **Hook Point** closer or further away from needle. (Getting Hook Point close to needle but not touching.)
42. Once adjustment has been made, using a Flathead Screwdriver, **tighten** set screw closest to Hook Point.
 43. **Rotate** gangshaft to **Color Change Position**. (Rotate degree wheel to 244 degrees).
 44. Using Needle Screwdriver, **loosen** needle set screw.
 45. **Rotate** Needle to correct position. (Groove facing front and scarf is in back).
 46. Using Needle Screwdriver, **tighten** needle set screw.
 47. To check for correct adjustment, rotate gangshaft until **Hook Point** is behind needle. (Rotate degree wheel to 24 degrees).
 48. Hook Point should be directly behind needle and as close to needle as possible. (Should not cause needle to bend).
 49. If Hook Point Timing and Gap is adjusted properly, using Flathead Screwdriver, **tighten** two remaining set screws (furthest from hook point). *If adjustment is not properly set repeat the above steps until proper adjustment has been accomplished.*
 50. **Rotate** gangshaft to **Color Change Position**. (Rotate degree wheel to 244 degrees).

*If removed Hook Assembly as instructed in **Section B** proceed to **Position Finger Adjustment***

*If Hook Assembly was **not** removed proceed to **Step 54**.*

51. Using Needle Screwdriver, **loosen** needle set screw.
52. **Rotate** needle to correct position. (Groove facing front and scarf is in back).
53. Using Needle Screwdriver, **tighten** needle set screw.
54. **Reinstall** throat plate.
55. Using 2.5 mm Allen Wrench, **tighten** throat plate screws.
56. **Reinstall** bobbin case in Hook Assembly.
57. Using enclosed disk, **sew** the “**HOX**” **test** to check for proper adjustment.

POSITION FINGER ADJUSTMENT

DEFINITION:

The Position Finger secures the hook basket in place and guides the bobbin thread to fabric.

CAUSES:

- < Replaced Hook Assembly.
- < Position Finger set screw not secure.

TOOLS NEEDED Offset Screwdriver

SYMPTOMS:

- < Bobbin thread underside of garment not centered.
- < No bobbin thread-"looping".

PROCEDURE:

1. **Engage** Needle Bar Driver. (If Hook Assembly was removed as instructed in Hook Timing the Needle Bar Driver has been engaged already.)
2. **Rotate** gangshaft until needle reaches it's lowest point, **Bottom Dead center**. (On Embroidery Machine rotate degree wheel [numbers ascend] to **zero degrees** this is called **Bottom Dead Center**.)
3. Using an Offset Screwdriver, **loosen** Position Finger screw.
4. **Move** Position Finger **left or right**, centering Position Finger Nose with needle. See Figure 1.

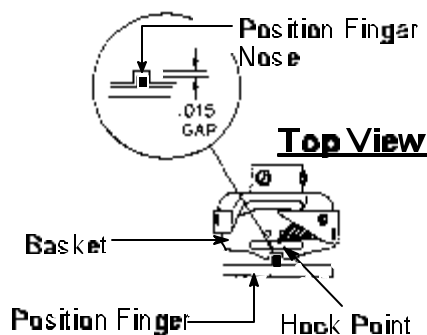

Figure 1

NOTE: Bobbin thread may not be centered if adjustment is incorrect.

5. Move Position Finger Nose **forward or back** from hook basket allowing enough clearance for thread to pass between easily. See *Figure 2*.

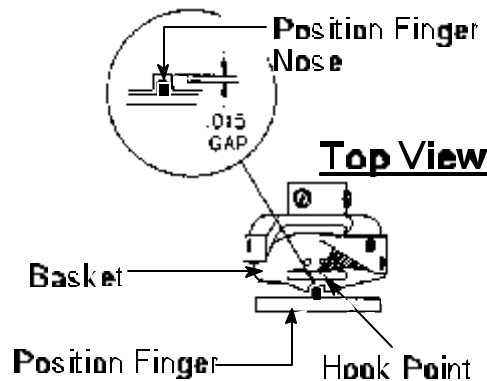

Figure 2

NOTE: If Position Finger Nose is too close to hook basket, birdnesting or thread breaks may occur

6. While holding Position Finger in place, **tighten** Position Finger **screw**.
7. **Rotate** gangshaft to **Color Change Position**. (Rotate degree wheel to 244 degrees).
8. **Reinstall** throat plate.
9. Using 2.5 mm Allen Wrench, **tighten** throat plate screws.

10. **Reinstall** bobbin case in Hook Assembly.
11. Using enclosed disk, **sew** the “**HOX**” **test** to check for proper adjustment.

NEEDLE BAR REPLACEMENT

DEFINITION:

The Needle Bar holds the needle and moves up and down.

CAUSES:

- < Bent
- < Burrs
- < Lack of Lubrication

SYMPTOMS:

- < Little or no movement up or down.
- < Skip Stitches.
- < Breaking needles

TOOLS NEEDED

3 mm Allen Wrench
Phillips Screwdriver
Needle Screwdriver
New Needles
New Needle Bar
New Small Spring
Flashlight

PROCEDURE:

A. NEEDLE BAR REPLACEMENT

1. **Using** Automat/Controller position damaged Needle Bar to left or right of Needle Bar Driver. *See Note.*

Note: If Needle Bar is damaged on **Needles 1-8**, position Sewing Head to Needle **#9**.
If Needle Bar is damaged on **Needle 9**, position Sewing Head to Needle **#1**.

2. **Power down** Embroidery Machine.
3. **Disengage** Needle Bar Driver.

4. **Pull** Thread Keep Lever to **left** to disengage thread apron clamps. See *Figure 1*.

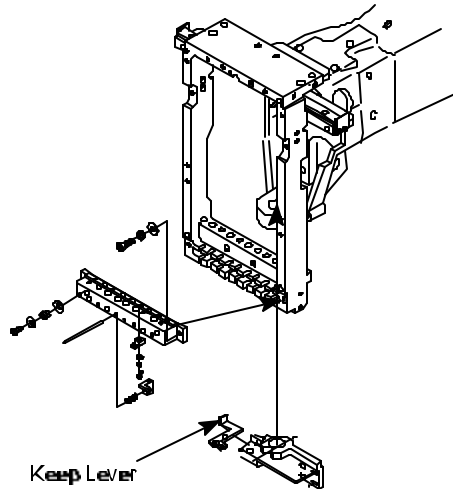

Figure 1

5. Using a Phillips Screwdriver, **remove** 6 Phillip Screws from A, B Sewing Head Plates and Thread Guide . See *Figure 2*.

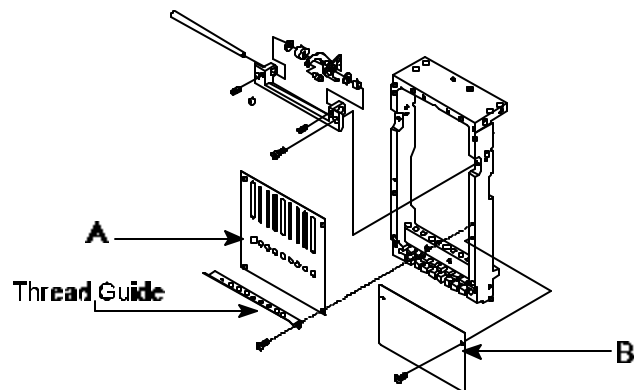

Figure 2

Note: When removing Sewing Head Plate **A** from **Sewing Head Number One**, lift straight up then pull towards you. Back side of cover wraps around the needle position indicator and incorrect

6. **Using** a 3 mm Allen Wrench **remove** 2-Allen Screws on the Take-up Lever Assembly.
7. **Remove** Take-up Lever Assembly.
8. Using a Needle Screwdriver, **loosen** needle set screw and **remove** needle.
9. **Squeeze** and **hold** Needle Bar and Presser Foot together and **remove** needle clamp, white spacer and 6.5 mm O-ring. See *Figure 3*.

10. Slowly **release** Needle Bar and Presser Foot.

11. **Move** Presser Foot down to its lowest position and **remove** 7 mm O-ring.
See *Figure 4*.

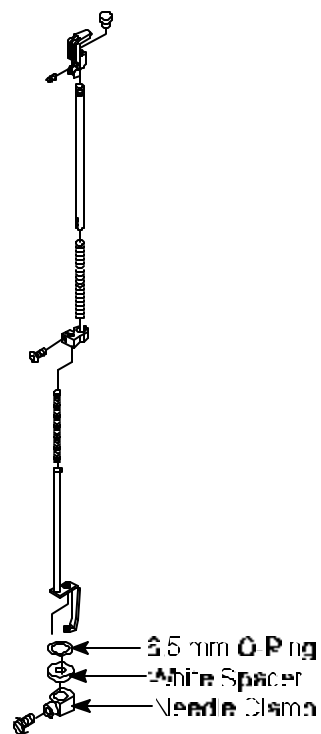

Figure 3

12. Carefully (springs may ricochet) **pull** Needle Bar and spring up and out of Slide Block.

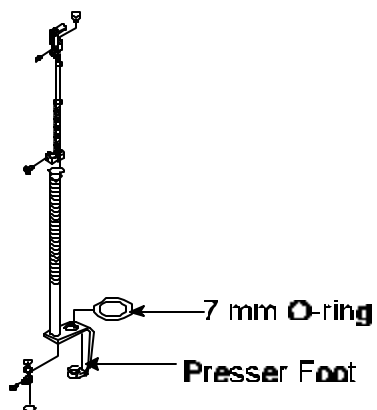

Figure 4

13. **Discard** old Needle Bar and Needle Bar Spring.
14. **Reposition** 7 mm O-ring over hole on top of Slide Block.
15. **Insert** new Needle Bar Spring onto new Needle Bar.

16. **Insert** new needle bar through Cloth Winder Stop Latch Set Clamp. See Figure 5.

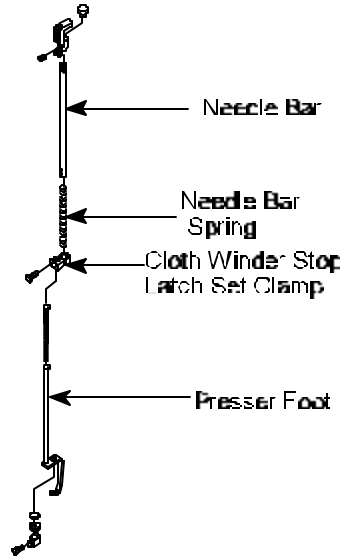

Figure 5

17. **Slide** Needle Bar through 7 mm O-ring positioned over hole on Slide Block. See Figure 6.

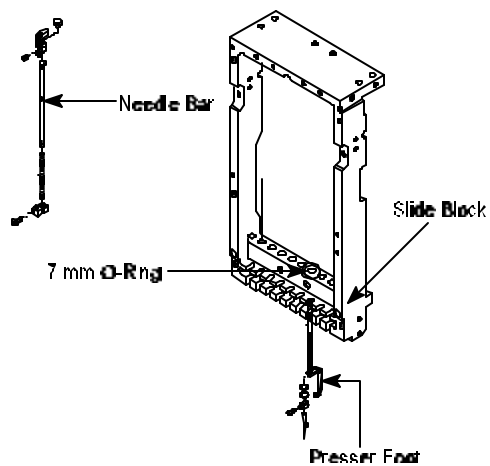

Figure 6

18. Continue **inserting** Needle Bar through Slide Block. See *Figure 6*.
19. **Press** Needle Bar down and **insert** 7 mm O-ring onto Needle Bar.
20. **Press** Needle Bar and Presser Foot together making sure Presser Foot Shaft lines up with Needle Bar Guide Notch.
21. While holding Needle Bar and Presser Foot together **slide** 6 mm O-ring and white spacer onto Needle Bar.
22. **Insert** Needle Clamp onto Needle Bar and align set screw with bottom hole then snug set screw.
23. **Insert** Needle correctly. (Groove facing front and scarf is in back).
24. Using a Needle Screwdriver, **tighten** Needle set screw.
25. While holding the Take-up lever assembly, **align** all Take-up Levers in the up position.
26. **Position** the Take-up Lever Assembly so back of Take-up levers notches slide onto the Stocker.

Note: If Positioned Sewing Head to **Needle #1**, position Take-up Lever **#1** on Take-up Lever Driver Roller.
If Positioned Sewing Head to **Needle #9**, position Take-up Lever **#9** on Take-up Lever Driver Roller.

27. **Using** a 3 mm Allen Wrench, **tighten** 2 Allen Screws to secure Take-up Lever Assembly.
28. Using Phillips Screwdriver, **replace** Sewing Head Plates and Thread Guide.

Helpful Hint: Replace bottom plate (B) first then top plate (A) and Thread Guide.

PRESSER FOOT REPLACEMENT

DEFINITION:

Presses down on material to prevent flagging.

CAUSES:

- < Bent
- < Damaged beyond repair

MOST PRESSER FEET CAN BE BENT BACK INTO SHAPE.

TOOLS NEEDED

2.5 mm Allen Wrench
Phillips Screwdriver
Needle Screwdriver
New Presser Foot
New Needle Bar Spring (lower)

SYMPTOMS:

- < Breaking needles
- < Needle Bar doesn't move freely
- < Presser foot damages material
- < Skipping Stitches

PROCEDURE:

A. REPLACING PRESSER FOOT

1. Using **Automat/Controller** position damaged Needle Bar to left or right of Needle Bar Driver. *See Note.*

Note: If Needle Bar is damaged on **Needles 1-8**, position Sewing Head to Needle **#9**.
If Needle Bar is damaged on **Needle 9**, position Sewing Head to Needle **#1**.

2. **Power down** Embroidery Machine.

3. **Disengage** Needle Bar Driver.
4. **Lower** drop table.
5. **Pull** Thread Keep Lever to **left** to disengage thread apron clamps. See *Figure 1*.

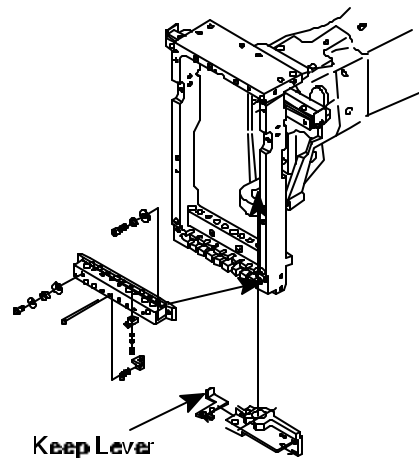

Figure 1

6. Using a Phillips Screwdriver, **remove** 6 screws from A, B Sewing Head Plates and Thread Guide . See *Figure 2*.

Note: When removing Sewing Head Plate **A** from **Sewing Head Number One**, lift straight up then pull towards you. Back side of cover wraps around the needle position indicator and incorrect removal can damage the indicator.

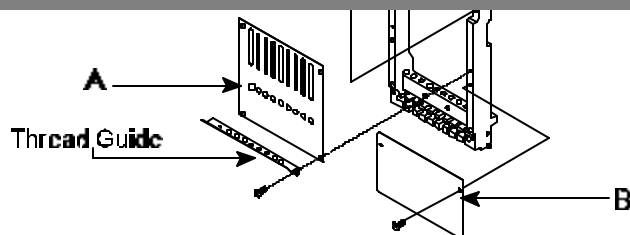

Figure 2

7. With 2.5 mm Allen Wrench **loosen** Cloth Winder Stop Latch Set Clamp.
See Figure 3.

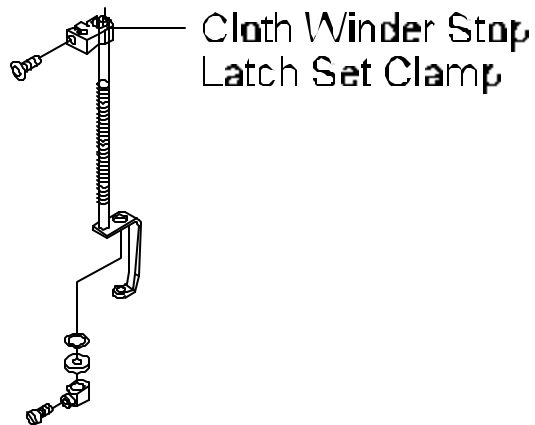

Figure 3

8. Using a Needle Screwdriver, **loosen** needle set screw and **remove** needle.
9. While Needle Bar remains lowered **remove** needle clamp, white spacer and 6.5 mm O-ring. See Figure 4.

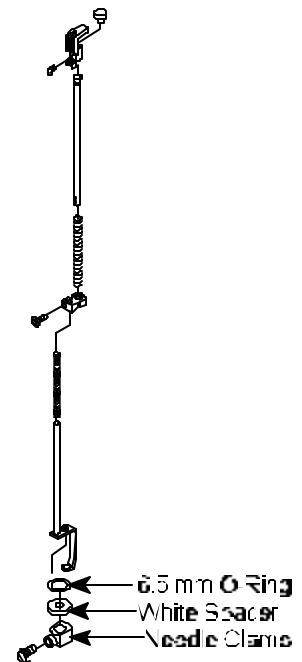

Figure 4

10. **Press** Presser Foot down to its lowest position and **remove** 7 mm O-ring.

See Figure 5.

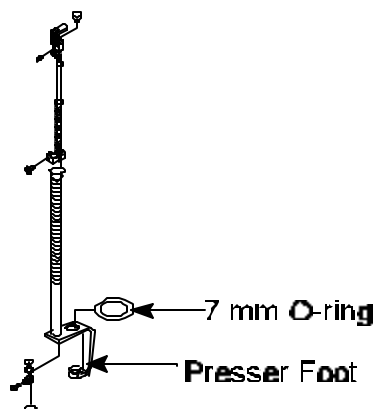

Figure 5

11. **Slide** damaged Presser Foot down and out.
12. Carefully (spring may ricochet) **pull** Presser Foot down and out of Slide Block.
13. **Remove** Presser Foot and Needle Bar Spring (lower). See Figure 6.

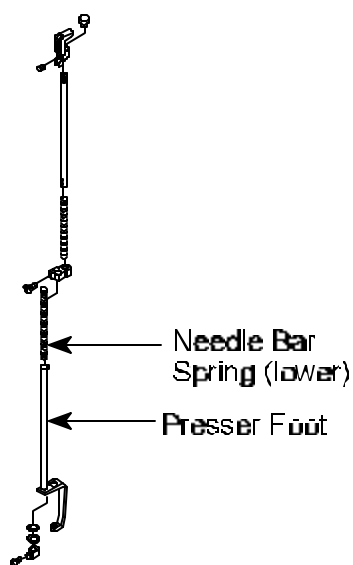

Figure 6

14. **Discard** old Needle Bar Spring (lower) and Presser Foot.
15. **Replace** and **position** new Needle Bar Spring above Slide Block opening.
16. Slide new Presser Foot up through Slide Block then through Needle Bar Spring (lower). See Figure 7.

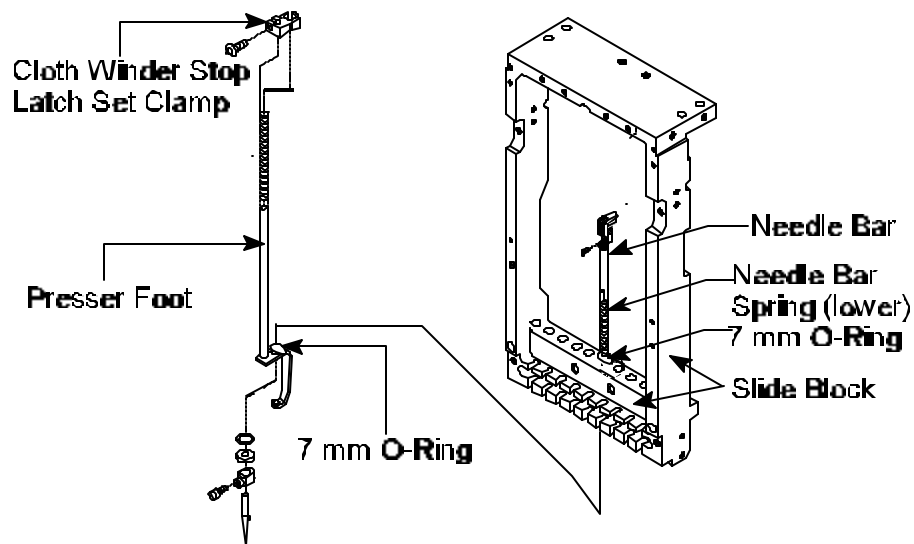

Figure 7

17. **Insert** Presser Foot through Cloth Winder Stop Latch Set Clamp. See Figure 7.
18. **Press** Needle Bar down and place 7 mm O-ring on Needle Bar.
19. Slide 6.5 mm O-ring and white spacer onto Needle Bar.
20. **Insert** Needle Clamp onto Needle Bar and align set screw with bottom hole then snug set screw.

21. **Measure** from top of Presser Foot 72 mm and adjust bottom of Cloth Winder Stop Latch Set Clamp to measurement. See Figure 8.

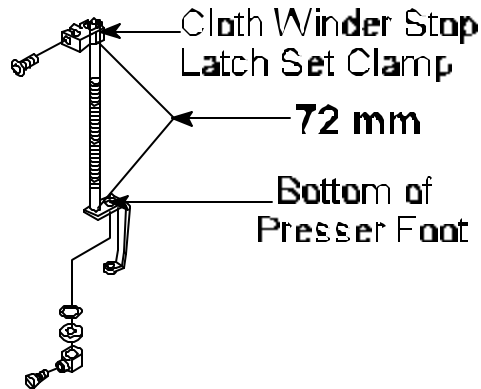

Figure 8

22. Using 2.5 mm Allen Wrench, **secure** Cloth Winder Stop Latch Set Clamp with hex socket bolt. See Figure 8.
23. **Insert** Needle correctly. (Groove facing front and scarf is in back).
24. Using Phillips Screwdriver, **replace** Sewing Head Plates and Thread Guide.

Helpful Hint: Replace bottom plate (B) first then top plate (A) and Thread Guide.

25. Using enclosed disk, **sew** the “HOX” test to check for proper adjustment.

TAKE-UP LEVER REPLACEMENT

DEFINITION:

Pulls the thread through the fabric after the stitch has been made, controlling the flow of thread during stitch formation.

CAUSES:

- < Improper Color Change
- < Improper replacement
- < Wear and tear
- < "Slam" into hoop

TOOLS NEEDED

- 2 mm T-Handle Allen Wrench
- 3 mm T-Handle Allen Wrench
- Phillips Screwdriver
- New Take-Up Lever (s)

SYMPTOMS:

- < Improper Movement
- < Breaking Stitches

PROCEDURE:

1. **Power** down Embroidery machine.
2. **Using** a Phillips Screwdriver **remove** 4 Phillip Screws from A Plate and Thread Guide. See Figure 1.

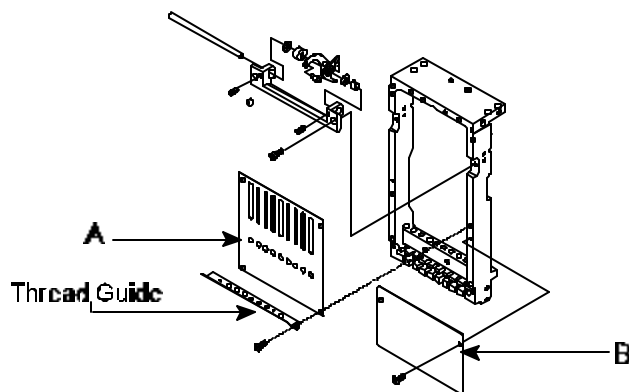

Figure 1

Note: When removing Sewing Head Plate **A** from **Sewing Head Number One**, lift straight up then pull towards you. Back side of cover wraps around the needle position indicator and incorrect removal can damage the indicator.

3. **Using** a 3 mm Allen Wrench, **loosen** and **remove** 2 hex socket bolts. See Figure 2.

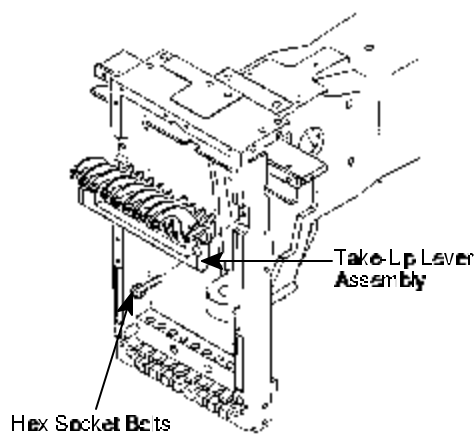

Figure 2

4. **Remove** Take-up Lever Assembly.

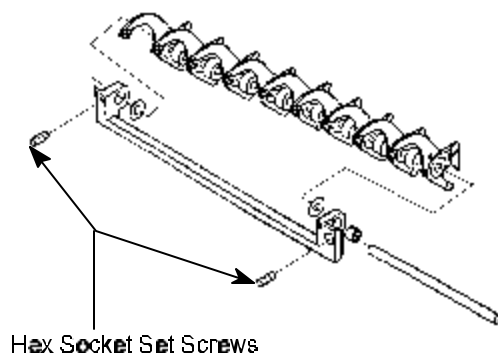

Figure 3

5. **Using** a 2 mm Allen Wrench, **loosen** two hex socket set screws. See Figure 3.

Helpful Hint: Remove Take-Up Levers over a table.

6. **Using** 2 mm Allen Wrench, **Push** and **Slide** Take-Up Lever Shaft out until the damaged Take-Up Lever can be removed.
7. **Remove** damaged Take-Up Lever.
8. **Replace** with new Take-Up Lever.
9. **Slide** Take-Up Lever Shaft through all Take-Up Levers, Take-Up Lever Spacer &

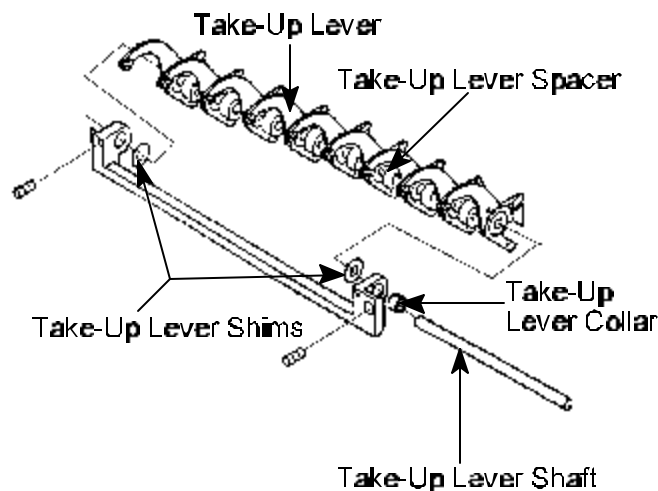

Figure 4

Take-Up Lever Shim. (If pushed Take-Up Lever Shaft from **right** replace Take-Up Lever Collar).
See Figure 4.

10. **Using** 2 mm Allen Wrench, **tighten** 2 hex socket set Screws.

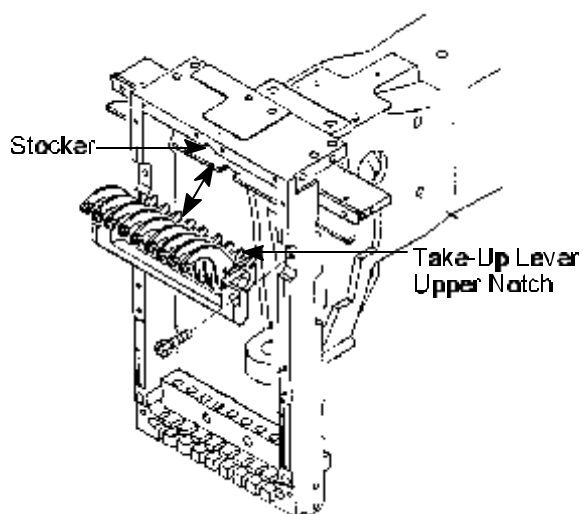

Figure 5

11. **Align** Take-Up Lever Upper Notches to Stocker. See *Figure 5*.

12. **Adjust** Take-Up Lever Assembly Alignment Marks to Slide Block Alignment Marks. See *Figure 6*.

13. **Using** 3 mm Allen Wrench, **tighten** 2 hex socket bolts to secure Take-Up Lever Assembly.
14. **Replace** Sewing Head Plate A and Thread Guide.

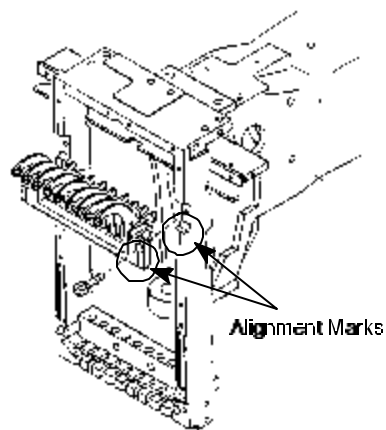

Figure 6

NEEDLE BAR DRIVER AND FIXING BASE REPLACEMENT

DEFINITION:

Drives the Needle Bar down.

CAUSES:

- < Lack of oil on Needle Bar
- < Improper replacement
- < Wear and tear
- < "Slam" into hoop

SYMPTOMS:

- < Skipping Stitches
- < Breaking Stitches
- < Excessive noise

TOOLS NEEDED

2 mm Allen Wrench
2.5 mm Allen Wrench
3 mm T-Handle Allen Wrench
Phillips Screwdriver
Offset Phillips Screwdriver
Needle Screwdriver
Flashlight

PROCEDURE:

1. Using **Automat/Controller** position Sewing Heads to **Needle #1**.
2. **Power down** Embroidery Machine.
3. **Disengage** Needle Bar Driver.

- Using a Phillips Screwdriver, **remove** 6 screws from A, and B Sewing Head Plates and Thread Guide . See Figure 1.

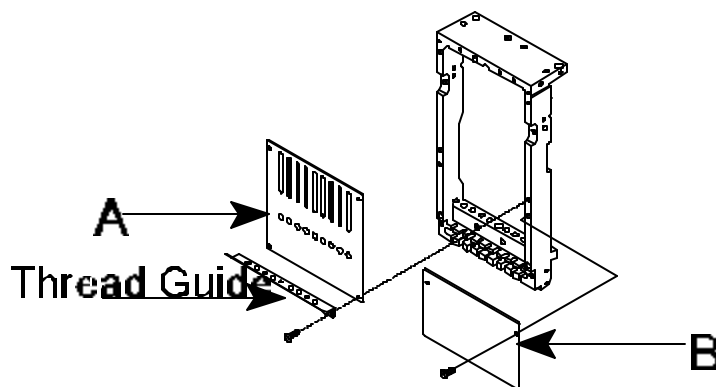

Figure 1

Note: When removing Sewing Head Plate **A** from **Sewing Head Number One**, lift straight up then pull towards you. Back side of cover wraps around the needle position indicator and incorrect removal can damage the indicator.

- Using** an Offset Phillips screwdriver, **remove** Phillips screws from Side Cover (Left). See Figure 2.

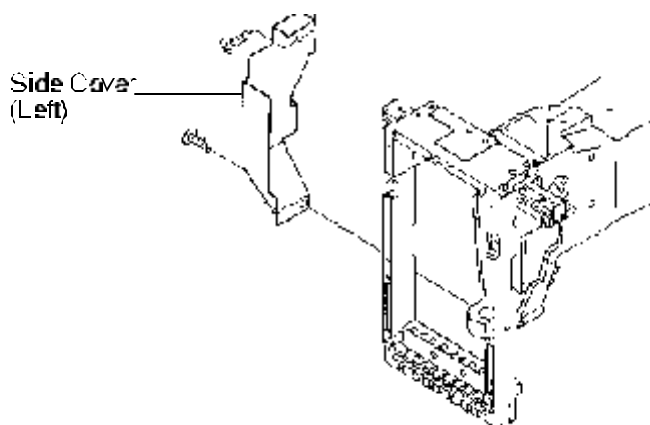

Figure 2

6. **Remove** Side Cover (Left).
7. **Remove** Needle Bar Driver Return Spring from post.
10. **Using** a 3 mm Allen Wrench, **remove** 2 hex socket bolts securing the Needle Bar Driver Fixing Base. See Figure 4.

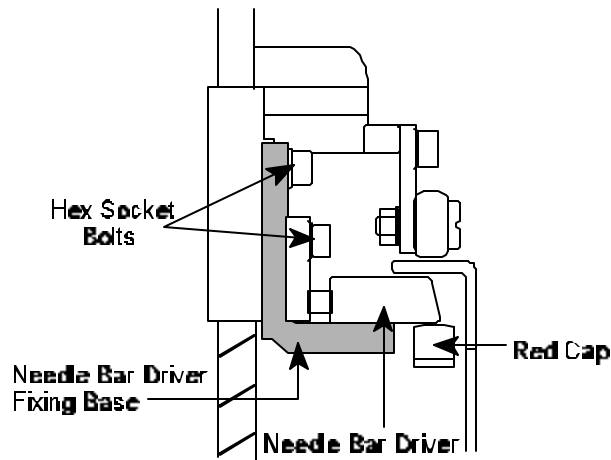

Figure 4

11. **Remove** Needle Bar Driver Fixing Base.
12. **Using** a 2 mm Allen Wrench, **loosen** 2 set screws securing the Needle Bar Driver.
13. **Remove** Needle Bar Driver and Needle Bar Driver Fixing pin from Needle Bar Driver Fixing Base. See Figure 5.

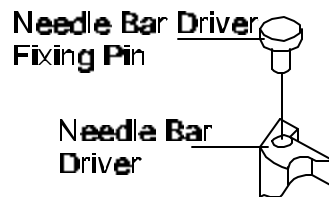

Figure 5

14. **Remove** Needle Bar Driver Fixing Pin from damaged Needle Bar Driver.
15. **Discard** damaged Needle Bar Driver.

16. **Replace** Needle Bar Driver Fixing Pin into **new** Needle Bar Driver.
17. **Check** for damage to Needle Bar Driver Fixing Base. (If damaged replace).
18. **Using** a 2 mm Allen Wrench, **remove** 2 set screws from damaged Needle Bar Driver Fixing Base.
19. **Discard** damaged Needle Bar Driver Fixing Base.
19. **Install** 2 set screws into new Needle Bar Driver Fixing Base **using** a 2 mm Allen Wrench.
18. **Place** Needle Bar Driver Fixing Pin through Needle Bar Driver then **install** on new Needle Bar Driver Fixing Base. (While holding the Needle Bar Fixing Base towards you-Needle Bar Driver is in front view, make sure the Needle Bar Driver Return Spring hole is facing the left). *Figure 6*

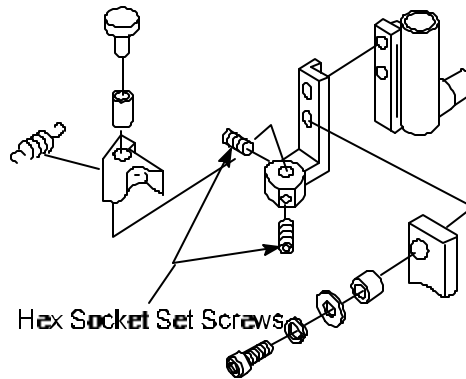

Figure 6

19. **Using** a 2 mm Allen Wrench, **tighten** 2 set screws to secure Needle Bar Driver on Needle Bar Driver Fixing Base.

20. **Replace** Needle Bar Driver Return Spring to Needle Bar Driver.
20. **Align** Driver Fixing Base Spacer behind Needle Bar Driver Fixing Base making sure both holes are aligned.
21. **Engage** Needle Bar Driver.
22. **Align** both Driver Fixing Base Spacer and Needle Bar Driver Fixing Base to Needle Bar Driver Guide Block.
23. **Using** a 3 mm Allen Wrench, **install** Hex Socket Bolt (12 mm in length) into upper hole. (Do not tighten completely). See Figure 6.

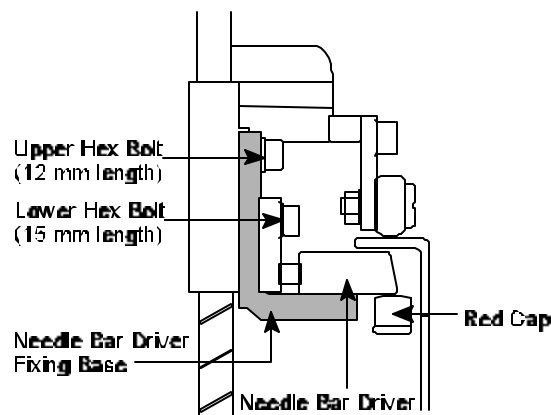

Figure 6

24. **Using** a 3 mm Allen Wrench, **install** Hex Socket Bolt (15 mm in length) through Needle Bar Driver Stopper and Needle Bar Driver Stopper Set Collar into lower hole. (Do not tighten completely). See Figure 6 & 7.

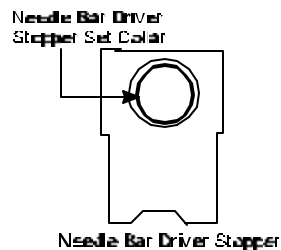

Figure 7

25. **Attach** Needle Bar Driver Return Spring to post.
26. Using a 2.5 mm Allen Wrench, **remove** throat plate screws.
27. **Remove** throat plate.
28. **Remove** bobbin case from Hook Assembly.
29. Using **cleaning brush**, clean any thread debris or lint from hook area.
34. **Remove** thread from Needle #1.
35. Using Needle Screwdriver, **loosen** needle set screw.
36. **Remove** and **discard** old needle.
37. **Insert new needle** correctly. (Groove facing front and scarf is in back.)
See *Figure 9*.

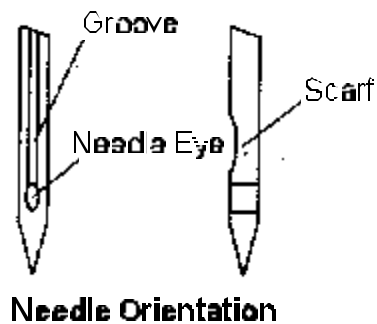

Figure 9

38. Using Needle Screwdriver, **tighten** needle set screw.
39. **Engage** Needle Bar Driver.
40. **Rotate** gangshaft so needle is at its lowest point (**Bottom Dead Center**). (Rotate degree wheel to **zero degrees** this is called **Bottom Dead Center**).